

# 6.5t Self indicating dynamometer (SID)



Designed to replace outdated mechanical products still in the field, this 14,300lb (6500kg) Dynamometer, the 'SID', is the latest Crosby SP product to feature their self indicating display.

This self-indicating version of the well-known product 'Bluelink' has advanced features and benefits, providing solutions where close-up load monitoring is required, such as when operating lever or chain hoists at height or lifting vehicle motors.

The advanced microprocessor-based electronics provide the SID with high-speed read rates, extreme resistance to industrial-level noise and unprecedented stability. It features full-function push button controls for:

- Tare and preset tare
- Selectable measurement units (lbs, kg, kN and tonnes)
- 100Hz high-speed peak hold
- Audible set-point alarm
- Overload counter

Providing accurate load measurement and incident and injury prevention this dynamometer is rigged using industry-standard shackles such as Crosby G2130, the compact design minimises headroom loss (6.14" or 156mm from eye to eye).

Constructed with high-grade aircraft quality aluminium and with a safety factor of 6:1, its lightweight design does not sacrifice on strength in fact Crosby SP's link style dynamometers are on average 30% lighter than those of other suppliers.

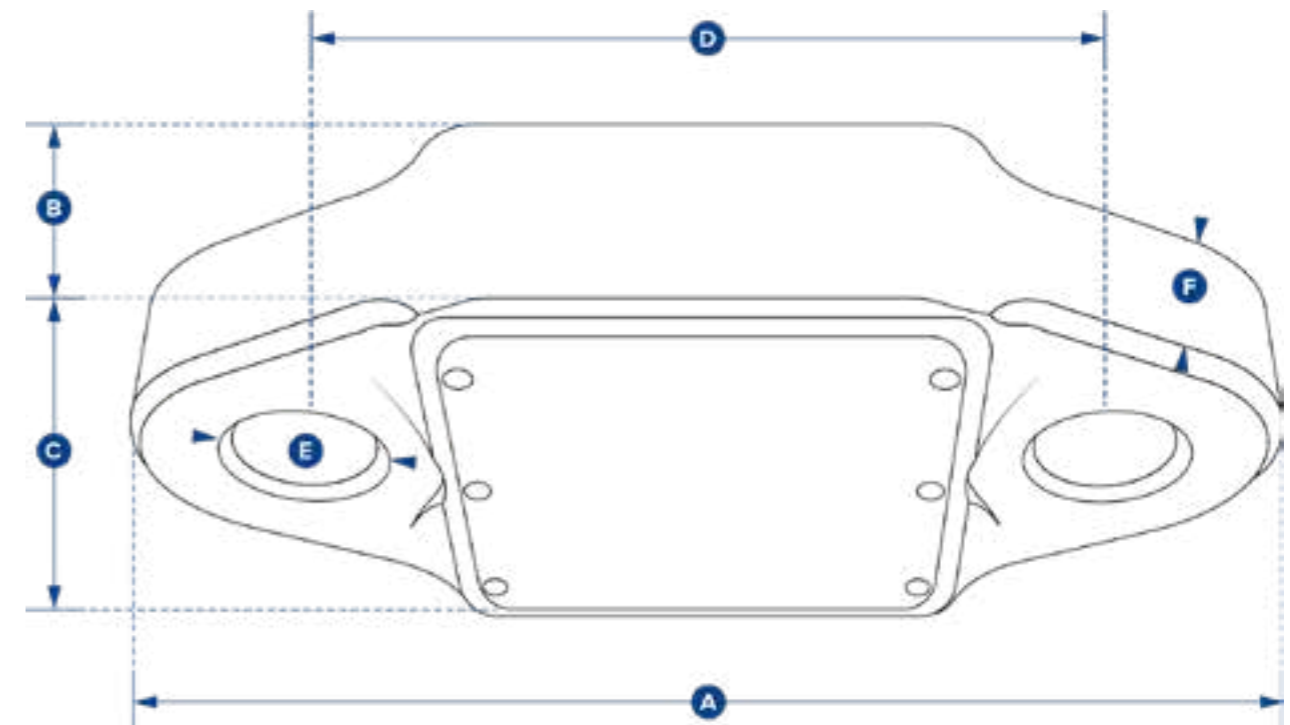

## FEATURES & BENEFITS

- Large 1" / 25mm LCD display
- 0.2% high accuracy
- Overload counter
- 90db Audible set point alarm
- RS-485 serial output
- IP65 / NEMA 4X
- Design validated by F.E.A.
- 2-year warranty

## APPLICATIONS

- Aircraft (engine) installation & maintenance
- Rigged with gantry crane
- Steel beam fabrication
- General weighing
- Transportation tie downs
- Towing
- Linesman tensioning

Part Number	SID6T5
Crosby Part	2789709
Capacity	6.5 te
	14,300 lb
Resolution	0.001 te
	2 lb
Weight	1.5 kg
	3.3 lb
Safety Factor	6:1
Battery Type	9v PP3
Battery Life	80 hrs continuous
Operating Temp	-10 to +50° C / 14 to 122° F
Accuracy	+/- 0.2% of full scale
Display Type	6 digit 25 mm LCD / 6 digit 1 in LCD
Protection	IP65 / NEMA 4X
Dimension A	224
	8.82
Dimension B	44
	1.73
Dimension C	113
	4.45
Dimension D	156
	6.14
Dimension ØE	27.5
	1.08
Dimension F	33
	1.3
Crosby Shackle	G2130
Loading Pin Ø	25
	1 in